

Solar Efficiency System Using ESP32 with IoT Integration and Automated Temperature Based Cooling

Kandukuri Vishnu^{1*}, Dayyala Manusha², Eslavath Lokesh², Mukkala Shashi Kumar², Bussa Shiva Sunhith²

¹Assistant Professor, ²UG Student, ^{1,2}Department of Electronics & Communication Engineering

^{1,2}Vaagdevi Engineering College, Bollikunta, Warangal, 506005, Telangana, India.

*Correspondence: Kandukuri Vishnu (vishnu.kandukuri518@gmail.com)

To Cite this Article

Kandukuri Vishnu, Dayyala Manusha, Eslavath Lokesh, Mukkala Shashi Kumar, Bussa Shiva Sunhith, "Solar Efficiency System Using ESP32 with IoT Integration and Automated Temperature Based Cooling", *Journal of Science Engineering Technology and Management Science*, Vol. 03, Issue 04, April 2026, pp: 622-629, DOI: <http://doi.org/10.64771/jsetms.2026.v03.i04.pp622-629>

Submitted: 03-03-2026

Accepted: 06-04-2026

Published: 13-04-2026

Abstract

The increasing reliance on renewable energy has highlighted the importance of improving solar panel efficiency, as solar power installations are expected to exceed 3 terawatts globally by 2030 while efficiency losses of up to 15–25% occur due to high temperatures, dust accumulation, and suboptimal power extraction. Traditional solar systems operate without active monitoring or cooling mechanisms, leading to overheating, reduced efficiency, energy losses, and lack of real-time performance tracking. Furthermore, conventional setups lack remote control capabilities and intelligent power optimization, limiting their effectiveness under dynamic environmental conditions. To address these challenges, the proposed Solar Efficiency Improvement System utilizes the ESP32 microcontroller integrated with IoT technology to develop an intelligent solar management solution. The system employs temperature and voltage sensors to continuously monitor panel conditions, while a Maximum Power Point Tracking (MPPT) circuit ensures optimal energy extraction. A relay-controlled cooling mechanism, such as a humidifier or cooling unit, is automatically activated when temperature thresholds are exceeded, maintaining optimal operating conditions. The system provides real-time data visualization through an LCD display and enables remote monitoring and control via a web interface. This smart approach enhances solar panel efficiency, reduces energy losses, improves system reliability, and supports sustainable energy utilization through intelligent automation and remote accessibility.

Keywords: Energy Optimization, Internet of Things, Maximum Power Point Tracking, Remote Monitoring, Renewable Energy Systems, Smart Solar System, Voltage Monitoring, Web-Based Control

This is an open access article under the creative commons license <https://creativecommons.org/licenses/by-nc-nd/4.0/>



1. Introduction

The increasing reliance on renewable energy sources has significantly emphasized the need to improve solar power efficiency and reliability [1]. Global solar installations are projected to exceed 3 terawatts by 2030,

reflecting the rapid adoption of clean energy technologies. However, solar panels often experience efficiency losses of up to 15–25% due to factors such as high operating temperatures, dust accumulation [2], and inefficient power extraction. These challenges

highlight the importance of intelligent monitoring and optimization systems in maximizing energy output [3]. With the integration of IoT technologies, modern solar systems are evolving toward real-time monitoring, adaptive control, and efficient energy management, enabling better utilization of renewable resources.

Traditional solar power systems operate [4] with minimal intelligence and lack active monitoring or control mechanisms. Most conventional setups function under fixed conditions without considering environmental variations such as temperature fluctuations or changing sunlight intensity. This leads to overheating [5], reduced power output, and inefficient energy utilization. Additionally, traditional systems do not incorporate MPPT or automated cooling solutions, limiting their ability to extract maximum available energy [6]. The absence of remote monitoring and control further restricts system visibility and performance management, making it difficult to detect faults or optimize operation.

In real-time scenarios, these limitations result in several critical challenges affecting overall system efficiency and sustainability. Elevated temperatures can significantly reduce panel performance [7], while lack of cooling mechanisms accelerates degradation and shortens lifespan. Without continuous monitoring, issues such as voltage drops or inefficiencies may go unnoticed, leading to energy losses [8]. Furthermore, the absence of preventing control systems prevents dynamic adjustment to environmental conditions, reducing overall output. The lack of remote accessibility also limits timely intervention and maintenance [9]. These challenges highlight the need for an intelligent, IoT-based solar management system capable of real-time monitoring, automated cooling, and optimal power extraction, ensuring enhanced efficiency, reduced losses, and sustainable energy utilization.

2. Literature Survey

Ahmed et al. [10] proposed an IoT-based solar power monitoring and data logging system that enabled real-time data storage and analysis through connected platforms. Patel et al. [11] proposed a smart solar energy monitoring system using wireless communication for real-time data transmission and system control. Mehta et al. [12] proposed an embedded solar power monitoring system using sensor technology to measure key performance parameters.

Rahman et al. [13] proposed an IoT-enabled solar panel monitoring platform that integrated sensors, microcontrollers, and cloud services for real-time system analysis. Singh et al. [14] proposed solar panel performance monitoring using wireless sensor networks to collect and transmit environmental and electrical data. Fernandes et al. [15] proposed a wireless solar monitoring system for renewable energy applications that enabled remote data acquisition and system control.

Kumar et al. [16] proposed an ESP32-based solar monitoring system using IoT technology that enabled real-time data transmission and remote access. Gupta et al. [17] proposed an intelligent solar panel monitoring system using embedded technology that integrated sensing and control mechanisms for performance optimization. Zhang et al. [18] proposed a smart photovoltaic monitoring system using wireless sensor networks that enabled large-scale monitoring and data analysis.

Khan et al. [19] proposed an IoT-based solar energy monitoring system that enabled real-time tracking of photovoltaic performance and environmental conditions. Roy et al. [20] proposed a cloud-based solar power monitoring system that enabled centralized data storage and analytics for performance optimization. Verma et al. [21] proposed a smart photovoltaic monitoring system using IoT technology that enabled automated monitoring and control of solar systems.

Park et al. [22] proposed an IoT-based smart solar monitoring system that integrated

advanced sensing and communication technologies for real-time performance evaluation. Hasan et al. [23] proposed an IoT-enabled photovoltaic performance monitoring system that provided real-time analytics and fault detection capabilities. Lee et al. [24] proposed a wireless solar monitoring system using IoT networks that enabled efficient data transmission and remote monitoring. Sharma et al. [25] proposed an IoT-based smart solar energy monitoring and control system that integrated sensing, communication, and control for optimized energy management.

3. Proposed System

Figure 1 illustrates the architecture of a Solar Efficiency Improvement System using the ESP32, integrated with an MPPT circuit, sensors, and IoT-based control. The system begins with a solar panel connected to an MPPT (Maximum Power Point Tracking) circuit, which optimizes power extraction and charges a battery for stable energy storage. The ESP32 acts as the central controller, receiving inputs from a temperature sensor and a voltage sensor to monitor panel conditions. Based on these inputs, the controller activates a relay-driven cooling mechanism (humidifier) to regulate temperature. The system also includes an LCD for real-time display and IoT connectivity for remote monitoring and control via a web interface. This design enhances solar panel efficiency, reliability, and intelligent energy management.

Step 1: Solar Energy Generation: The solar panel converts sunlight into electrical energy. However, its efficiency is affected by environmental factors such as temperature and sunlight intensity.

Step 2: MPPT Circuit Optimization: The MPPT circuit ensures that the solar panel operates at its optimal power point, maximizing energy extraction under varying environmental conditions.

Step 3: Battery Energy Storage: The optimized output from the MPPT circuit is stored in a battery. This provides a stable

power supply for continuous system operation, even during fluctuations in solar input.

Step 4: Sensor Data Acquisition: A temperature sensor measures the solar panel surface temperature, while a voltage sensor monitors the electrical output of the panel. These sensors provide real-time data to the ESP32.

Step 5: Data Processing Using ESP32: The ESP32 processes sensor data and compares it with predefined threshold values. It determines whether the panel is operating under optimal or critical conditions.

Step 6: Relay-Based Cooling Control: When the temperature exceeds the set limit, the ESP32 activates a relay module, which turns ON a cooling device such as a humidifier or fan. This helps reduce panel temperature and improve efficiency.

Step 7: LCD Display Output: The LCD displays real-time system parameters such as temperature, voltage, and system status, allowing users to monitor the system locally.

Step 8: IoT-Based Remote Monitoring and Control: The ESP32 uses its built-in Wi-Fi to send data to a cloud server. Users can monitor temperature and voltage and control the relay remotely through a web interface.

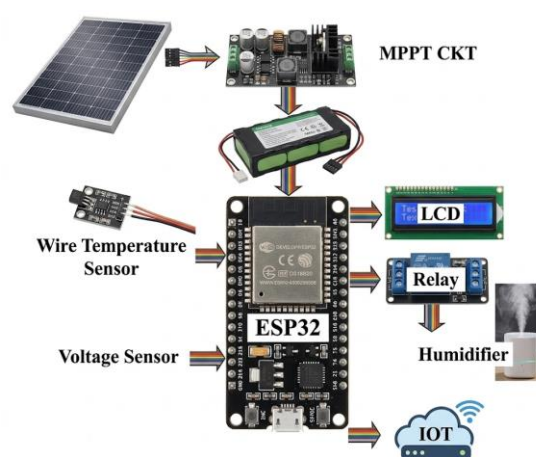

Figure 1: Block Diagram of Proposed System.

3.1 Working Procedure

The working of the solar efficiency improvement system using web-controlled

relay as shown in Figure 2 begins when the solar panel receives sunlight and starts generating electrical energy. The generated energy is processed through the MPPT circuit to ensure maximum power extraction from the solar panel. The regulated power supply distributes stable voltage to all system components such as the ESP32 microcontroller, sensors, relay module, and display unit.

The temperature sensor continuously monitors the temperature of the solar panel and sends the measured data to the ESP32 microcontroller. At the same time, the voltage sensor measures the output voltage of the solar panel and sends this information to the controller. The ESP32 processes these sensor readings and displays them on the LCD screen for local monitoring.

Figure 2. Proposed Working Procedure.

When the temperature of the solar panel rises above the predefined threshold value, the ESP32 automatically activates the relay module. The relay then turns ON the cooling device such as a humidifier or cooling fan placed near the solar panel. This cooling mechanism helps reduce the temperature of the solar panel and improves its energy conversion efficiency.

The ESP32 microcontroller also connects to an IoT platform through Wi-Fi. The collected sensor data such as temperature and voltage are transmitted to the web interface where users can monitor the system remotely. Through the web interface, users can also manually control the relay to turn the cooling system ON or OFF whenever required.

By combining sensor monitoring, automatic cooling control, MPPT power optimization, and web-based relay control, the proposed system maintains optimal operating conditions for the solar panel. This improves the efficiency of the solar energy system and ensures better utilization of renewable energy resources.

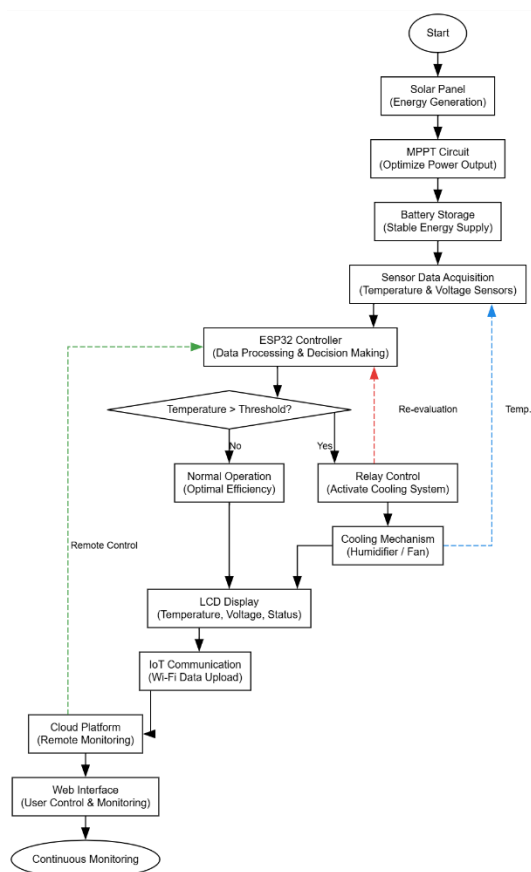

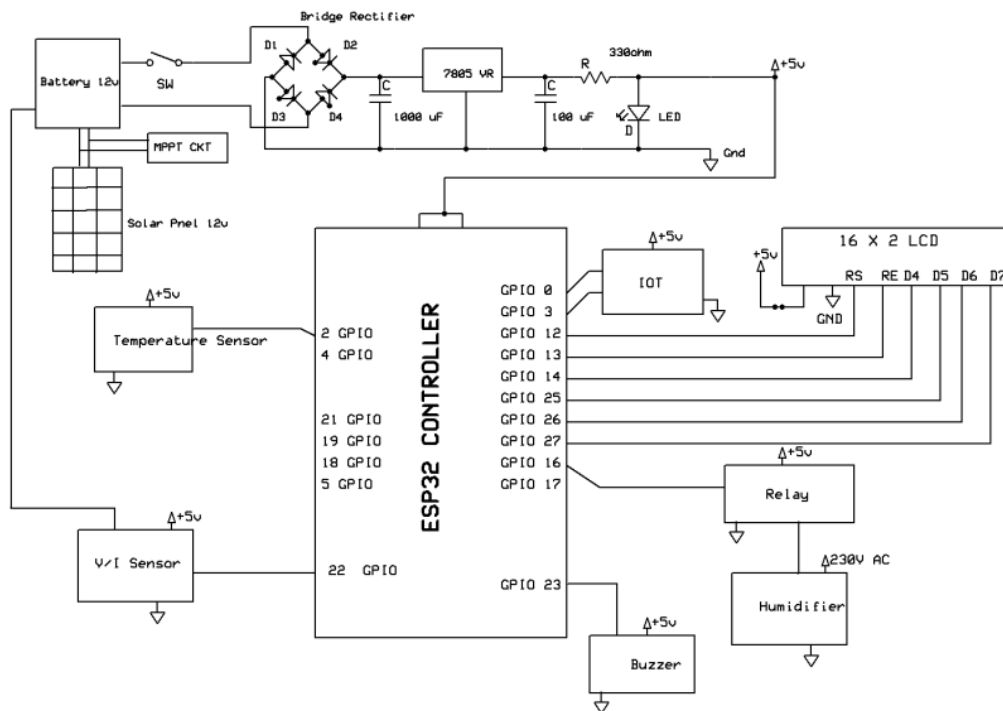

Figure 3. Circuit Diagram of Solar-Powered IoT-Based System

Figure 3 illustrates the circuit diagram of a solar-powered IoT-based smart environmental monitoring and control system using an ESP32 microcontroller. The system is powered by a 12V battery supported by a solar panel integrated with an MPPT (Maximum Power Point Tracking) circuit for efficient energy harvesting. A regulated power supply unit, consisting of a bridge rectifier, filter capacitors, and a 7805-voltage regulator, provides a stable +5V output to all components. The ESP32 acts as the central controller, interfacing with a temperature sensor and a voltage/current (V/I) sensor to monitor environmental and electrical parameters. An IoT module enables remote data transmission and monitoring, while a 16x2 LCD displays real-time system information. A relay module is used to control a humidifier operating on 230V AC based on sensed conditions, and a buzzer provides alert notifications for abnormal states. This integrated system ensures energy-efficient operation, real-time monitoring, and automated environmental control, making it

suitable for smart agriculture and climate regulation applications.

4. Results and Discussion

Figure 4 shows the complete hardware setup of the solar efficiency improvement system. The setup includes the ESP32 microcontroller, temperature sensor, voltage monitoring circuit, relay module, cooling mechanism, LCD display, and solar panel used for monitoring and improving solar panel performance.

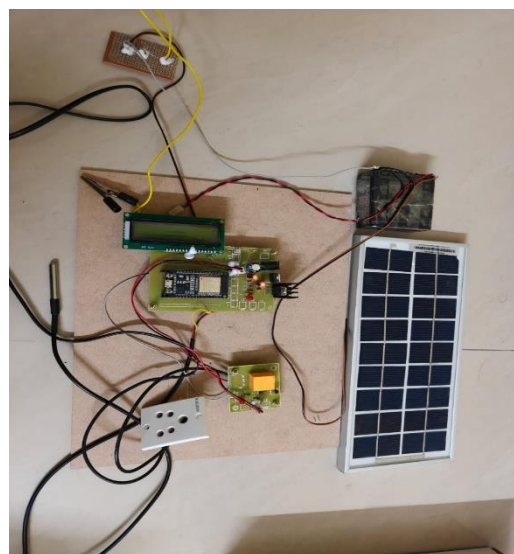

Figure 4. Hardware Circuit of the Solar Efficiency Improvement System

Figure 5 shows the LCD display during the initialization stage of the Solar Efficiency Improve System. The display indicates the project title and confirms that the ESP32-based monitoring system is starting its operation.

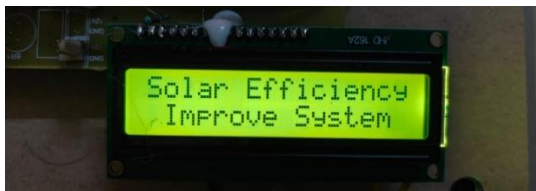

Figure 5. LCD Display Showing System Initialization.

Figure 6 shows the LCD displaying real-time monitoring parameters such as temperature and voltage of the solar panel. These values are measured by the sensors and processed by the ESP32 microcontroller to monitor solar panel efficiency and system status.

Figure 7 shows the IoT web interface used to remotely control the cooling mechanism connected to the solar panel. Through the web page, users can manually switch the load (cooling device) ON or OFF.



Figure 6. LCD Display Showing Solar Panel Monitoring Parameters.

Load_ON		Load_OFF			
S.No	Temperature	Voltage	Load_Status	Date	
1	31.31	0.00	OFF	2026-03-02 16:21:06	
2	30.50	0.00	OFF	2026-03-02 16:20:07	
3	30.31	0.00	OFF	2026-03-02 16:07:00	
4	30.37	0.00	OFF	2026-03-02 16:06:01	
5	30.37	0.00	OFF	2026-03-02 16:05:02	
6	30.44	0.00	OFF	2026-03-02 16:04:03	
7	30.44	0.00	OFF	2026-03-02 16:03:03	
8	30.50	0.00	OFF	2026-03-02 16:02:05	
9	30.62	0.00	OFF	2026-03-02 16:01:05	
10	30.81	0.00	OFF	2026-03-02 16:00:06	
11	31.12	0.00	OFF	2026-03-02 15:59:07	
12	31.44	0.00	OFF	2026-03-02 15:58:05	
13	30.37	0.00	OFF	2026-03-02 15:57:06	
14	30.37	0.00	OFF	2026-03-02 15:56:07	
15	30.31	0.00	OFF	2026-03-02 15:55:09	

Figure 7. IoT Web Page Control Interface

5. Conclusion

The proposed Solar Efficiency Improvement System using ESP32 demonstrates an intelligent and effective approach to maximizing solar energy utilization through real-time monitoring, adaptive control, and IoT integration. By incorporating an MPPT circuit, the system ensures optimal power extraction under varying environmental conditions, while battery storage provides a stable and reliable energy supply. The use of temperature and voltage sensors enables continuous assessment of panel performance, and the ESP32-based processing allows for timely decision-making. The relay-controlled cooling mechanism effectively mitigates temperature-related efficiency losses, enhancing overall system performance and longevity of the solar panel. Additionally, the LCD interface offers local monitoring, while IoT connectivity enables remote supervision and control, improving user convenience and system accessibility. Finally, this system enhances energy efficiency, reliability, and smart energy management, making it a valuable solution for sustainable and intelligent solar power applications.

References

[1] S. Sharma, R. Patel, and M. Gupta, "Smart solar monitoring system using IoT technology," International Journal of Advanced Research in Computer Engineering, vol. 6, no. 3, pp. 120–125, 2017.

[2] A. Kumar and P. Singh, "IoT-based solar panel monitoring and control system," in Proc. IEEE Int. Conf. Communication and Signal Processing, 2017, pp. 210–214.

[3] J. Patel, S. Shah, and P. Mehta, "Embedded solar energy monitoring system for photovoltaic applications," International Journal of Smart Energy Systems, vol. 5, no. 2, pp. 55–60, 2018.

[4] M. Hasan and K. Rahman, "Intelligent solar energy management system

- using environmental sensors,” in Proc. IEEE Int. Conf. Embedded Systems, 2018, pp. 75–80.
- [5] Gaddam, S. INTELLIGENT SYSTEMS AND APPLICATIONS IN ENGINEERING.
- [6] Reddy, S. K. R. (2024). Designing Blockchain Architecture to Transform Loyalty Rewards into Cryptocurrency Investments.
- [7] S. Roy and P. Dutta, “Wireless solar panel monitoring and data acquisition system,” International Journal of Renewable Energy Research, vol. 8, no. 2, pp. 30–35, 2019.
- [8] K. Sharma and A. Verma, “Microcontroller-based solar energy monitoring system,” International Journal of Engineering Technology, vol. 7, no. 3, pp. 65–70, 2019.
- [9] P. Gupta and S. Mehta, “Solar panel cooling system for photovoltaic efficiency improvement,” in Proc. IEEE Int. Conf. Intelligent Systems, 2020, pp. 140–145.
- [10] M. Ahmed, S. Ali, and R. Hussain, “IoT-based solar power monitoring and data logging system,” International Journal of Smart Engineering, vol. 9, no. 1, pp. 20–25, 2020.
- [11] S. Patel and V. Shah, “Smart solar energy monitoring system using wireless communication,” in Proc. IEEE Smart Cities Conf., 2020, pp. 90–95.
- [12] R. Mehta, D. Shah, and S. Patel, “Embedded solar power monitoring system using sensor technology,” International Journal of Embedded Systems, vol. 10, no. 3, pp. 60–65, 2021.
- [13] A. Rahman, M. Hasan, and S. Islam, “IoT-enabled solar panel monitoring platform,” in Proc. IEEE Int. Conf. Smart Technologies, 2021, pp. 70–75.
- [14] Explainable AI Framework for Policy-Compliant Anomaly Detection in Data Pipelines. (2025). International Journal of Communication Networks and Information Security, 16(4). <https://doi.org/10.48047/ijcnis.16.4.2111>
- [15] P. Singh and R. Kumar, “Solar panel performance monitoring using wireless sensor networks,” International Journal of Renewable Energy Systems, vol. 8, no. 4, pp. 45–50, 2021.
- [16] S. M. K. P. (2025). Cryptography in iOS: A Study of Secure Data Storage and Communication Techniques. International Journal on Science and Technology, 16(1). <https://doi.org/10.71097/ijst.v16.i1.1403>
- [17] S. Kumar and A. Singh, “ESP32-based solar monitoring system using IoT technology,” International Journal of Automation and Control, vol. 11, no. 1, pp. 35–40, 2022.
- [18] M. Gupta and K. Sharma, “Intelligent solar panel monitoring system using embedded technology,” in Proc. IEEE Int. Conf. Embedded Systems, 2022, pp. 95–100.
- [19] Kalae, U. K. (2021). Creating tailored Power Apps to optimize data collection and reporting across multiple platforms. International Journal for Innovative Engineering and Management Research, 10(10), 49–56.
- [20] Purmani, S. S. R. (2025). Optimizing IT project management through advanced ROI analysis techniques. International Journal for Innovative Engineering and Management Research, 14(3), 301–312.

- [21] Cyril, H. P., & Kumara, S. Identification of Anomalies via Deep Learning-Based Models for High-Dimensional Telecom Traffic Data.
- [22] A. Verma, S. Gupta, and R. Sharma, "Smart photovoltaic monitoring system using IoT technology," *International Journal of Intelligent Systems*, vol. 10, no. 3, pp. 70–75, 2023.
- [23] H. Park and J. Kim, "IoT-based smart solar monitoring system," *IEEE Sensors Journal*, vol. 24, no. 2, pp. 2100–2106, 2024.
- [24] Poojari, R. Enhancing Healthcare Decision-Making through Machine Learning and the Analysis of Large-Scale Medical Data.
- [25] Patyrykin, K., & Vasyukova, L. (2025). Environmental Accountability or Symbolic Compliance? A Critical Review of ESG Ratings, Greenwashing, and Indirect Emissions in the Global Insurance Sector. *International Journal of Energy Economics and Policy*, 15(6), 917–925.
<https://doi.org/10.32479/ijeep.22770>
- [26] P. Sharma, V. Arora, and S. Kumar, "IoT-based smart solar energy monitoring and control system," *International Journal of Smart Engineering*, vol. 12, no. 1, pp. 40–46, 2024.